



Three Bag Grass Catcher Adaptor Kit Manual

**Hustler FasTrak and Super Duty
(2081300 & 2081320)**

1380 Legion Road, Detroit Lakes, MN 56501

Phone: 800-725-7761

Fax: 888-385-2345

Email: sales@smtis.com

Website: ztrattachments.com

8/25/2010

TABLE OF CONTENTS

To The New Owner	2
Warranty see owner's manual	
Important Safe Operations Practices – See owners' manual	
Grass Catcher Installation.....	4
Assemble Bagger Assembly	4
Install Blower Housing	5
Attaching Chute	7
Operation.....	7
Parts List	9
Cut Out.....	

The operator's manual is an important part of your new grass catcher attachment. It will help you assemble and maintain your unit for best performance. Please read and understand all steps for installation and heed all warnings for use of attachment.

To The New Owner

The purpose of this manual is to assist owners and operators in installing and operating the grass catcher. Please read carefully; information and instructions furnished can help you achieve years of dependable performance.

The decals on the grass catcher are there to remind the operator about possible dangers the belt and chute can be if not used properly. These decals are not intended to be used in place of this manual but instead as an extension of this manual. These decals should not be removed or obliterated. Replace these decals if they become unreadable.

It is the OWNER'S RESPONSIBILITY to make certain all operators read and understand this manual and all decals before operating the grass catcher. It is also the OWNER'S RESPONSIBILITY to make certain that all operators are qualified and physically able individuals that are properly trained in the use of this equipment.

For any Questions Contact SMT Integrated Services, LLC at 1-800-725-7761



WARNING—YOUR RESPONSIBILITY

Restrict the use of this power machine to persons who can read, understand and follow the warnings and instructions in this manual and on the machine.



REPLACE THIS DECAL IMMEDIATELY IF IT THEY BECOMES UNREADABLE OR DAMAGED.

DANGER



- ▲ *Never engage mower deck unless transfer chute is attached in place on blower outlet.*
- ▲ *Use a probe to clean debris from spout.*
- ▲ *Keep all sheilds in place.*
- ▲ *Before servicing: Stop tractor engine. Remove ignition key. Be sure rotor has stopped.*
- ▲ *Do not operate unless deflector is in place and in lowest position or complete grass collection system is in place.*

PART #2010088

Assembly Instructions for Hustler FasTrak and Superduty

STEP 1 ASSEMBLE BAGGER ASSEMBLY

Install backend

Place back end frame on back bumper. Align hole in back end Frame with mower bumper and push all the way back to frame. Do not tighten completely until upper mount bolts are installed. (Use a vice grip to position back end frame on bumper during installation)

Parts:

- (2) 5/16 X 1" bolts, fender washer and nut
- (1) 5/8 X 1 1/4" bolt, washer & nylock nut
- (1) 2010099 Brace

Install bolt, washers and nut through back end frame and 2010099 Brace.

Fasten support arms to support bracket and existing hole in tractor frame.

Fasten fuel line bracket to support bracket being sure to position so line does not rub against metal.

Put bags in place on frame as shown in picture



Place lid on backend frame.

Line up hinges and insert bolts and washer into bottom holes. The top holes are for the pin that is used to keep lid locked down.

Parts:

(2) 3/8 X 1" bolt washers (each side) nylock nut

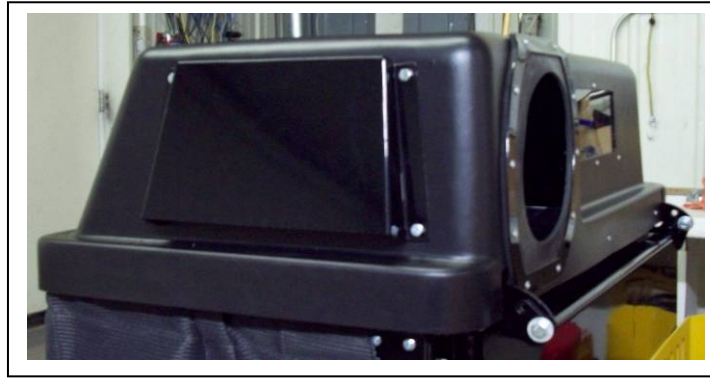

STEP 2 INSTALL BLOWER HOUSING

Install drive pulley

Remove pulley cover, unscrew bolt that attaches outside pulley. Install Pulley assembly on top of outside pulley. **Tighten to at least 85 ft lbs.**



Install mounting bracket

Raise deck to highest transport height. Remove plastic chute and bracket from deck and replace with bracket supplied.

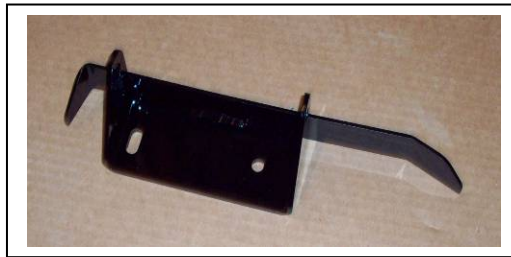

Place blower on installed bracket. Fasten as shown.

Install pin

Install nut and bolt

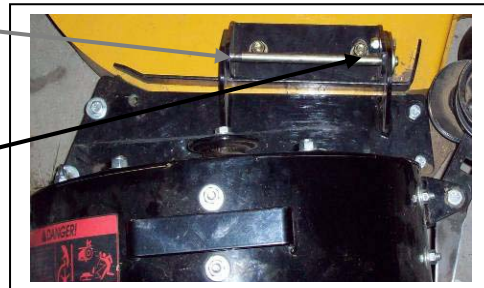

Belt Installation

Install belt as shown in picture; route belt with twists as shown in picture below. Use 1/2 inch drive socket wrench to position idler allowing for belt installation.



Install Belt Guards

Bolt
(FasTrak)

Slip guard under
washer and
attach rubber
strap.

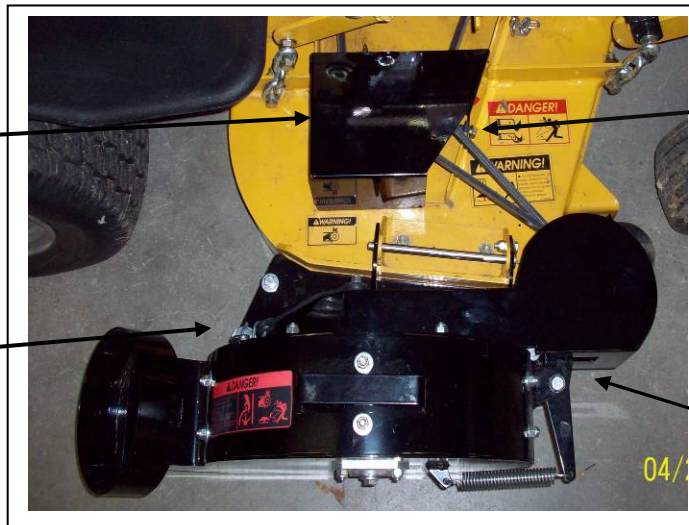

Bolt
(FasTrak)

Fit slot in
guard into
groove located
in lower idler
spacer.



ATTACHING THE CHUTE

See last 2 pages in booklet to locate the Optimal Angle & Length chart to find the Pin Points for your particular Make and Deck Sizes. H-59 & H-50 are the PINSET holes and are used for your reference.

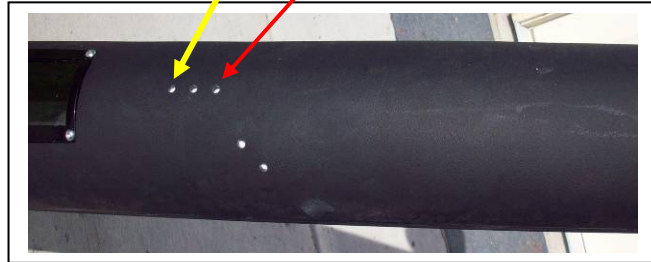

Use the chart in the manual as a layout tool on the tube to drill a 1/4" hole in the location found with the chart for your unit. This hole will line with the 1/4" hole located in the upper transition tube. Fasten the upper and lower tubes together using the 1/4-20 x 3/4 bolt and 1/4-20 nylock nut.

Insert the upper tube in the lid as shown. Place the lower end on the blower housing. Match the slot and attach the fastener.



Diagram 1: A



To remove shoot for service or inspection, disengage deck drive and shut off motor. For ease of tube removal, raise lid.



Operation



Warning: Read, understand, and follow all instructions and warnings on the tractor, attachment, and in the tractor and catcher Owner's Manuals before operating. Become familiar with and comfortable using your entire MOWERS controls as instructed in your Owner's Manual before operating it with the grass catcher attachment.

- Make certain the correct weight of motor oil is in your tractors engine as instructed in your owner's manual.
- Always operate the grass catcher with the engine at high rpm's
- NEVER override any safety feature on either your tractor or grass catcher.
- Make sure that all nuts, bolts, and hardware are fastened securely and tight on both the Concord Grass Catcher attachment and your tractor prior to use.
- Make certain the grass catcher is assembled properly and mounted to the mower deck as instructed in the Owner's Manual.
- Test all controls for proper operation prior to operating the grass catcher.
- Never place hands or feet into blower housing. There is an impeller located inside the housing that will cause sever injury.
- Never engage the mower deck unless chute is strapped in place on blower outlet.
- If the chute becomes jammed with grass, immediately disengage deck, place control lever in the park brake position, shut off engine, remove the key, and wait for blower to stop before unclogging. Always use a rod or stick to unplug blower housing or chute. Use a probe to clean debris from blower and spout.
- Do not operate on slopes greater than 15 degrees. Always attach the counter weight when using the Concord Grass catcher.

ITEM NO.	PART NUMBER	DESCRIPTION	QTY.
1	2081109	WELD GRASS BLOWER ASSEMBLY	1
2	2010038	belt tensioner arm, grass pump	1
3	2081110	WELD MOUNT	1
4	2010073	bushing	2
5	798223	Bearing flangette, triangular	4
6	601071	Bearing	2
7	791566	idler pulley, flat 3.25"	1
8	2010042	belt tensioner pulley spacer	1
9	C-601070	Drive pulley	1
10	2010134	Spring Belt tensioner	2
11	2010085	pulley spacer, lower	1
12	2010107	Belt tensioner spring spacer	4
13	Preferred Narrow FW 0.25		4
14	HBOLT 0.2500-20x1.75x0.75-N		2
15	108165	Impeller shaft	1
16	601065	Idler pulley "V" 3.00"	1
17	107915	Impeller	1
18	HBOLT 0.6250-11x3x1.5-N		1
19	2081111	grass pump liner	1
20	2010090	Belt guard, grass pump	1
21	Eye bolt .25-20 x .875		1
22	Regular LW 0.3125		2
23	fender washer .312		1
24	2010132	Tie down strap, rubber 6"	1
25	601073	impeller sapacer	1
26	FW 0.75		1

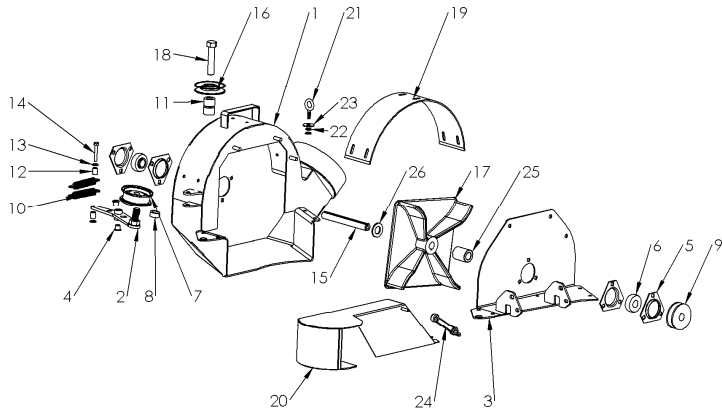

Grass Pump Assembly

ITEM NO.	PART NUMBER	DESCRIPTION	QTY.
1	2081000	Top assembly bag support	1
2	2010099	Brace, grass catcher	1
3	2010102	Bag mount brace, left, Hustler	1
4	2010103	Bag mount brace, right, Hustler	1
5	601228	Transition tube, Upper	1
6	601229	Transition tube, lower	1
7	2010093	Slight glass frame	1
8	2010092	sight lens	1
9	2010132	Tie down strap, rubber 6"	1
10	2010113	Foam Hood Seal	1
11	2081039	Hood vent	1
12	2010121	vent screen	1
13	2004012	Hopper cover	1
14	2081033	Lid Support Frame	1
15	2010080	Inlet tube seal support	1
16	2081041	Hood window	1
17	2010086	Inlet tube seal	1
18	2081070	Bag mount bracket	3
19	2010116	Bag hoop	3
20	2010120	grass bag	3

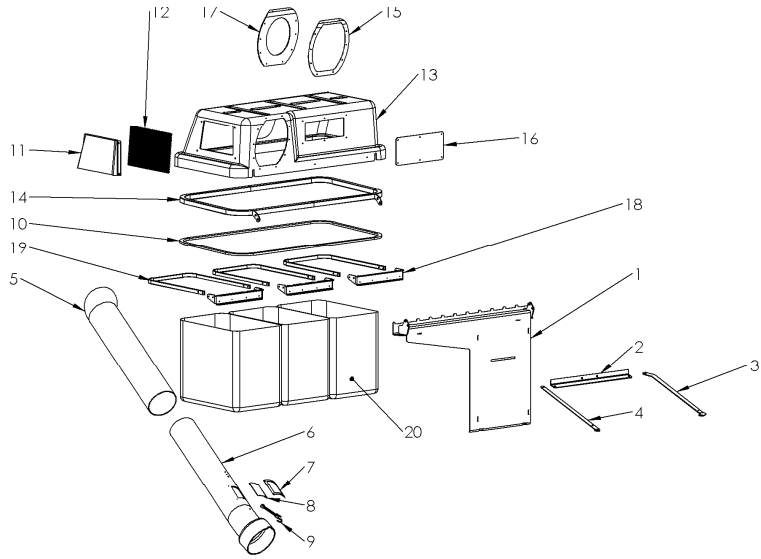

Catcher Assembly

Parts List FasTrak 48" Deck adaptor kit

2081300 48" DECK ADAPTOR KIT



- #1. BAGGED COMPONENTS
 - 2 – HHCS 5/16-18 X 1
 - 3 – HHCS 5/16-18 X 3/4
 - 3 – FLAT WASHER USS 5/16" ZINC
 - 5 – NYLOCK HEX NUT 5/16-18 ZINC
 - 1 – 1/4 -20 X 1/2 THUMBSCREW ZINC



- #2. AX-57 GATES TRI-POWER COGGED BELT



- #3. DECK/PUMP RETAINER PIN 108537



- #4. DRIVE PULLEY ASSEMBLY 2081304A



- #5. BELT GUARD – HUSTLER 48" DECK 2010084



- #6. BELT GUARD – INTERMEDIATE 48"/54" 2010089



- #7. DECK HANGER SUPPORT BRACKET 2081202



- #8. BAG MOUNT BRACE – LEFT – HUSTLER 2010102



- #9. BAG MOUNT BRACE – RIGHT – HUSTLER 2010103

Parts List FasTrak 54" Deck adaptor kit

2081320 54" DECK ADAPTOR KIT



#1. BAGGED COMPONENTS

- 2 – HHCS 5/16-18 X 1
- 3 – HHCS 5/16-18 X ¾
- 3 – FLAT WASHER USS 5/16" ZINC
- 5 – NYLOCK HEX NUT 5/16-18 ZINC
- 1 – 1/4 -20 X ½ THUMBSCREW ZINC
- 1 – DECK/PUMP SEAL ADPT. KIT 54"



#2. AX-60 GATES TRI-POWER COGGED BELT



**#3. DECK/PUMP RETAINER PIN
108537**



**#4. DRIVE PULLEY ASSEMBLY
2081304A**



**#5. BELT GUARD – HUSTLER 54" DECK
2010078**



**#6. BELT GUARD – INTERMEDIATE 48"/54"
2010089**



**#7. DECK HANGER SUPPORT BRACKET
2081202**



**#8. BAG MOUNT BRACE – LEFT – HUSTLER
2010102**



**#9. BAG MOUNT BRACE – RIGHT – HUSTLER
2010103**



1380 Legion Road
Detroit Lakes, MN 56578
Phone: 800-725-7761
Fax: 888-385-2345
<http://ztrattachments.com>